



US 20140225075A1

(19) **United States**
(12) **Patent Application Publication**
Zhan

(10) **Pub. No.: US 2014/0225075 A1**
(43) **Pub. Date: Aug. 14, 2014**

(54) **THIN FILM SEMICONDUCTOR DEVICE, ORGANIC LIGHT-EMITTING DISPLAY DEVICE, AND METHOD OF MANUFACTURING THE THIN FILM SEMICONDUCTOR DEVICE**

(52) **U.S. Cl.**
CPC *H01L 51/52* (2013.01); *H01L 29/78672* (2013.01)
USPC **257/40; 257/66; 438/151**

(71) Applicant: **Zhi-Feng Zhan**, Yongin-City (KR)

(57) **ABSTRACT**

(72) Inventor: **Zhi-Feng Zhan**, Yongin-City (KR)

(21) Appl. No.: **13/944,084**

(22) Filed: **Jul. 17, 2013**

(30) **Foreign Application Priority Data**

Feb. 14, 2013 (KR) 10-2013-0016052

Publication Classification

(51) **Int. Cl.**
H01L 51/52 (2006.01)
H01L 29/786 (2006.01)

Provided is a thin film semiconductor device such as an organic light-emitting display which includes a thin film transistor (TFT) having a lightly doped region. The thin film semiconductor includes a substrate, a first active pattern, a first lower conductive pattern, and a first upper conductive pattern. The first active pattern is disposed on the substrate and includes a channel region, a lightly doped region, and a heavily doped region. The first lower conductive pattern is disposed on the first active pattern and covers the channel region. The first upper conductive pattern is disposed on the first lower conductive pattern and covers the channel region and the lightly doped region.

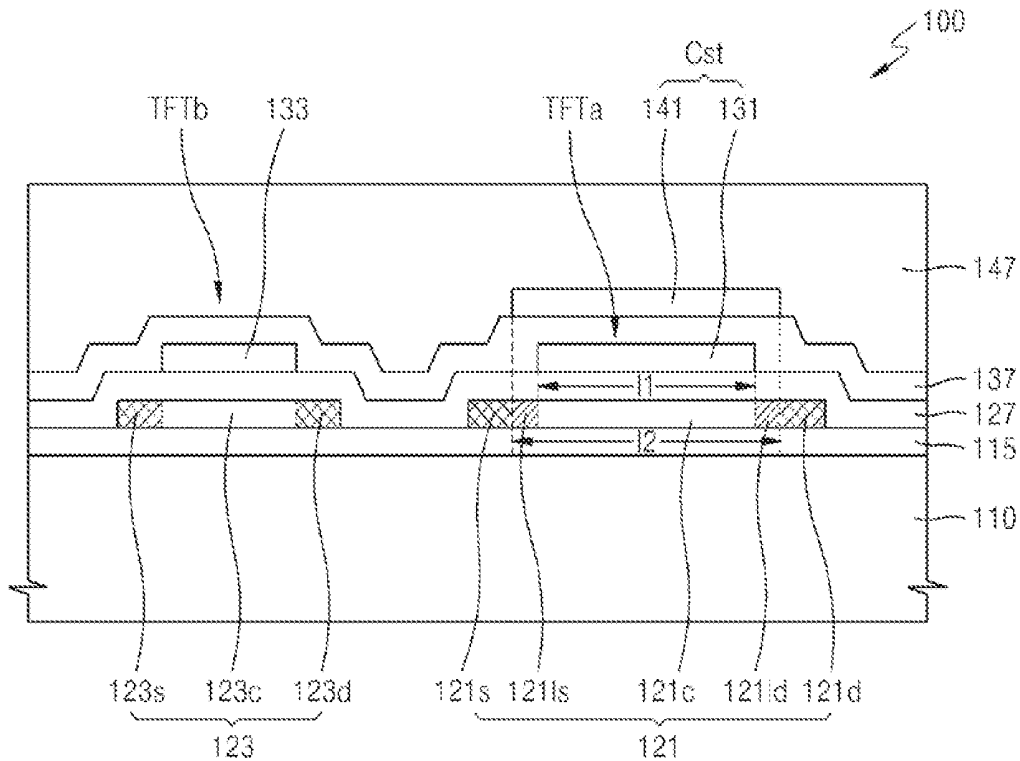

FIG. 2B

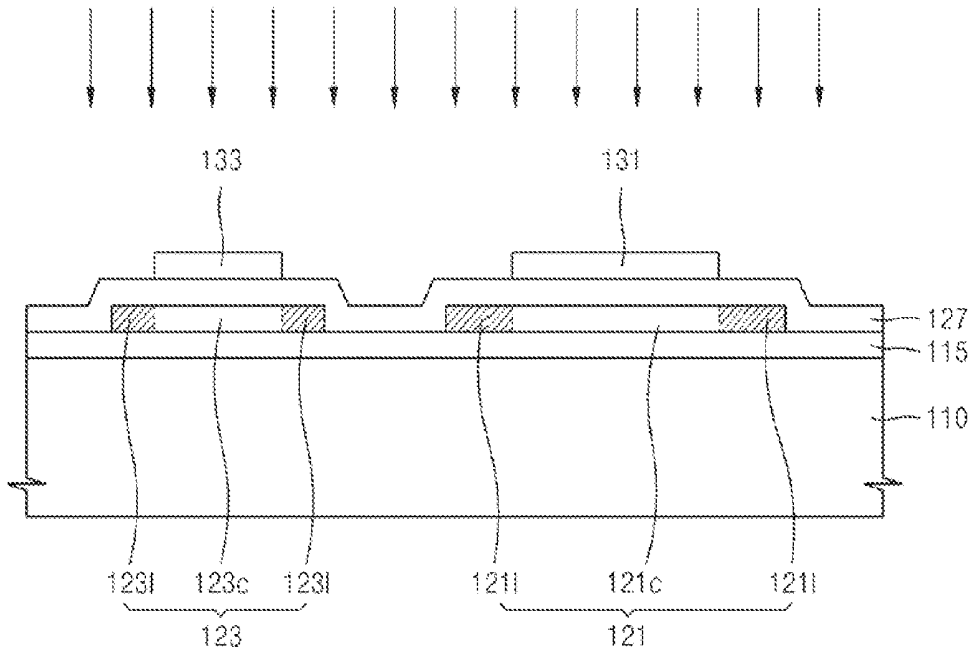

FIG. 2C

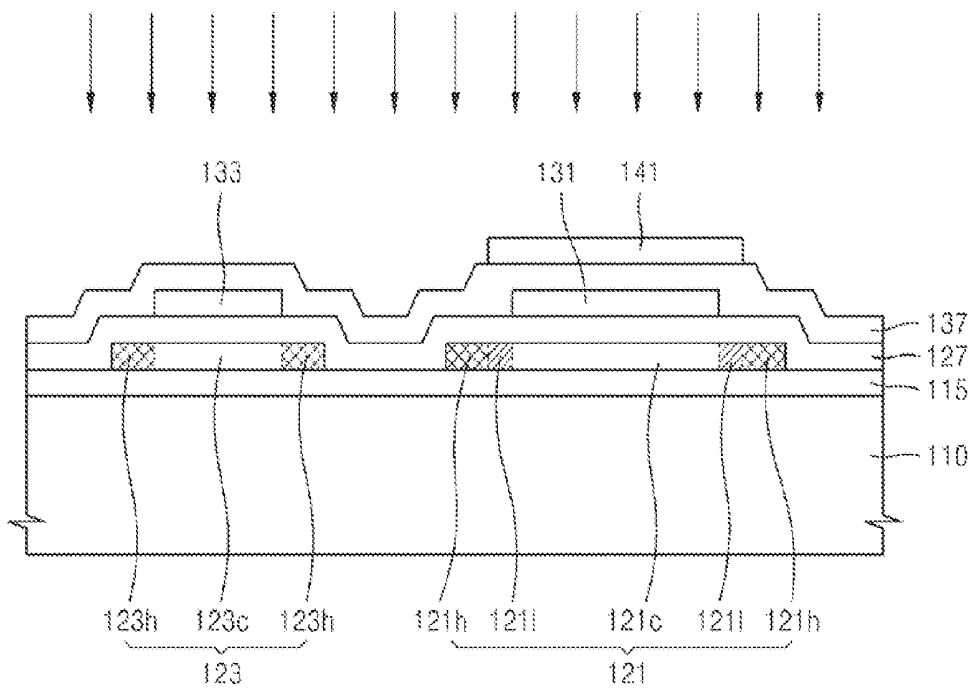

FIG. 3A

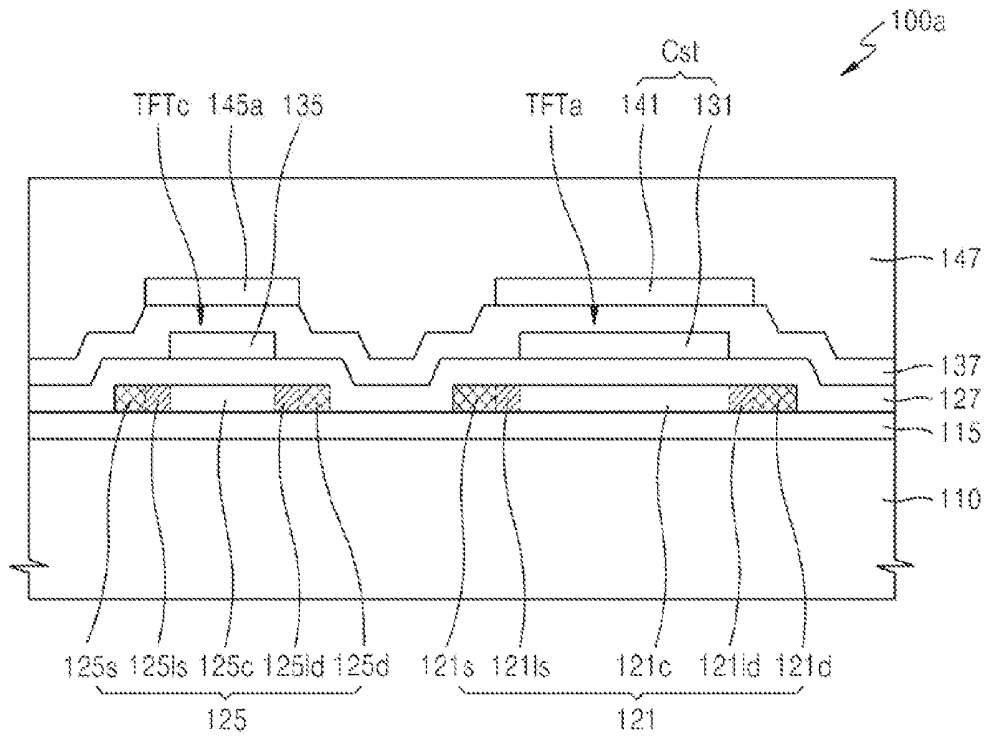

FIG. 3B

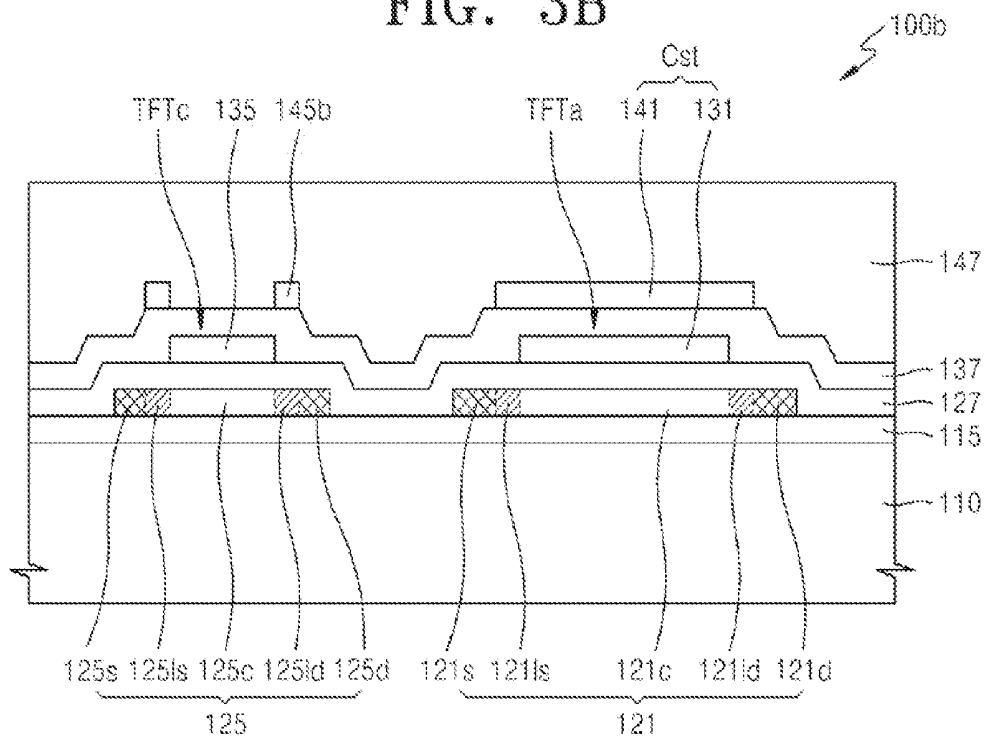

FIG. 5

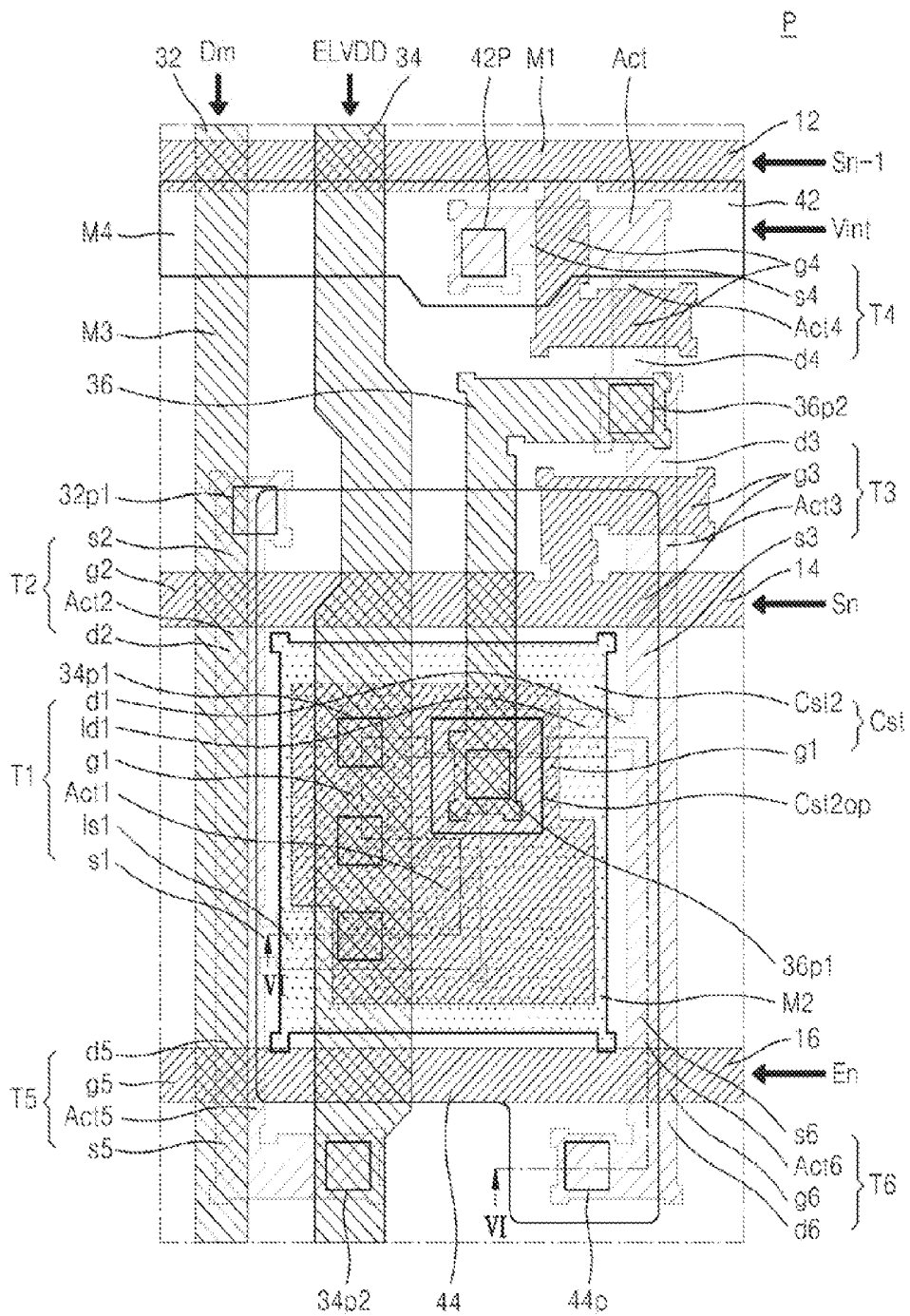
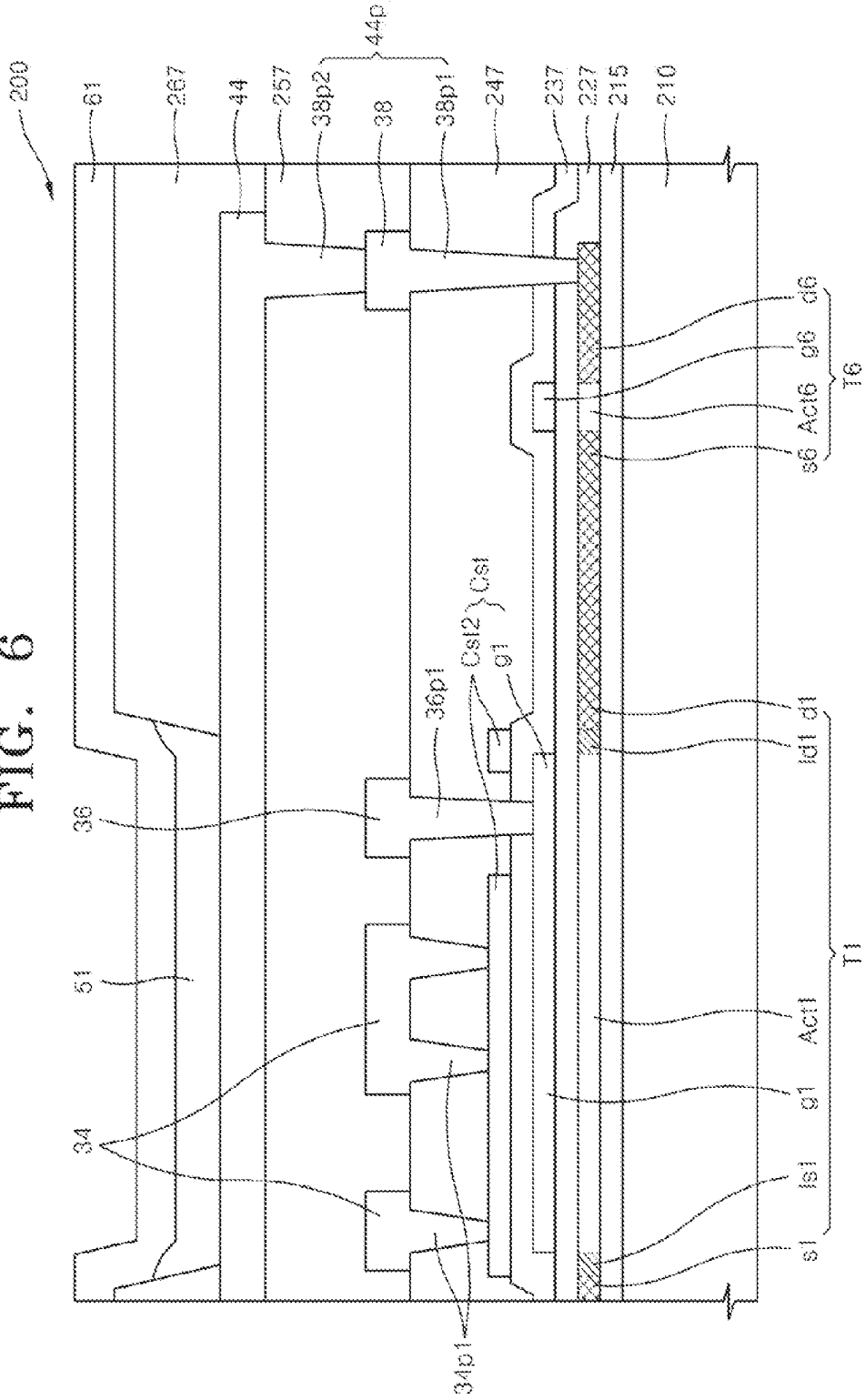

FIG. 6



**THIN FILM SEMICONDUCTOR DEVICE,
ORGANIC LIGHT-EMITTING DISPLAY
DEVICE, AND METHOD OF
MANUFACTURING THE THIN FILM
SEMICONDUCTOR DEVICE**

CLAIM OF PRIORITY

[0001] This U.S. non-provisional patent application claims priority under 35 U.S.C. §119 of Korean Patent Application No. 10-2013-0016052, filed on Feb. 14, 2013, the contents of which are hereby incorporated by reference in its entirety.

BACKGROUND OF THE INVENTION

[0002] 1. Field of the Invention

[0003] Embodiments of the present invention generally relates to a thin film semiconductor device such as an organic light-emitting display device, and more particularly, to a thin film semiconductor device such as an organic light-emitting display which includes a thin film transistor (TFT) having improved electrical characteristics.

[0004] 2. Description of the Related Art

[0005] Compared to a semiconductor device using a semiconductor substrate, when a thin film transistor (TFT) is formed by using a semiconductor thin film formed on a glass substrate, manufacturing costs may be reduced and a process for a large area may be easily performed, so that a thin film semiconductor device such as a flat panel display device is used in various fields.

[0006] An organic light-emitting display device is a self-emissive display apparatus that emits light and has characteristics of high brightness and a low operating voltage, so that the organic light-emitting display device has an excellent contrast ratio, can be formed as an ultra slim display apparatus, and is stable in realizing a moving picture at a response time of about several microseconds (its). Also, the organic light-emitting display device does not have a limit in a viewing angle, is stable at low temperatures, and is driven with a low voltage of about 5 to 15 V (direct current (DC)), so that it is easy to manufacture and design a driving circuit for the organic light-emitting display device, and the manufacturing process is simple.

[0007] The organic light-emitting display device includes TFTs and a capacitor so as to control emission by pixels. For example, a TFT includes a semiconductor pattern formed of polysilicon. The semiconductor pattern includes a channel region and impurity regions that are doped with impurity at sides of the channel region. Since a doping density sharply changes at a boundary between the impurity region and the channel region, a strong electric field may be induced. The strong electric field causes a short channel effect or a hot electron effect, such that leakage current is increased and an off-current characteristic deteriorates.

SUMMARY OF THE INVENTION

[0008] The present invention provides a thin film semiconductor device such as an organic light-emitting display device, and a method of manufacturing the thin film semiconductor device, whereby an electrical characteristic such as an off-current characteristic of a thin film transistor (TFT) can be improved while a total number of mask processes is not increased.

[0009] According to an aspect of the present invention, there is provided a thin film semiconductor device including

a substrate, a first active pattern, a first lower conductive pattern, and a first upper conductive pattern. The first active pattern is disposed on the substrate and includes a channel region, a lightly doped region, and a heavily doped region. The first lower conductive pattern is disposed on the first active pattern and covers the channel region. The first upper conductive pattern is disposed on the first lower conductive pattern and covers the channel region and the lightly doped region.

[0010] A boundary between the lightly doped region and the heavily doped region may correspond to an edge of the first upper conductive pattern. Also, a boundary between the channel region and the lightly doped region may correspond to an edge of the first lower conductive pattern.

[0011] The first active pattern and the first lower conductive pattern may configure a first thin film transistor (TFT), and the first lower conductive pattern may function as a gate electrode of the first TFT.

[0012] The first lower conductive pattern and the first upper conductive pattern may configure a capacitor.

[0013] The thin film semiconductor device may further include a lower gate insulating layer between the first active pattern and the first lower conductive pattern, and an upper gate insulating layer between the first lower conductive pattern and the first upper conductive pattern.

[0014] The heavily doped region may include a first heavily doped region and a second heavily doped region which are disposed at sides of the channel region. The lightly doped region may include a first lightly doped region between the channel region and the first heavily doped region, and a second lightly doped region between the channel region and the second heavily doped region.

[0015] The thin film semiconductor device may further include a second active pattern formed from the same layer as the first active pattern and including a source region, a drain region, and a channel region between the source region and the drain region, and a second lower conductive pattern formed from the same layer as the first lower conductive pattern and covering the channel region of the second active pattern. The second active pattern and the second lower conductive pattern may configure a second TFT. The second lower conductive pattern may function as a gate electrode of the second TFT.

[0016] The second active pattern may further include a lightly doped region between the channel region and one of the source region and the drain region. The thin film semiconductor device may include a second upper conductive pattern formed from the same layer as the first upper conductive pattern and covering the channel region and the lightly doped region of the second active pattern.

[0017] The second upper conductive pattern may be electrically connected to the second lower conductive pattern and thus may function as a common gate electrode of the second TFT.

[0018] The second upper conductive pattern may float.

[0019] According to another aspect of the present invention, there is provided an organic light-emitting display device including a substrate, a plurality of thin film transistors (TFTs) and a capacitor on the substrate, a pixel electrode electrically connected to one of the plurality of TFTs, a common electrode on the pixel electrode, and an intermediate layer disposed between the pixel electrode and the common electrode and including an emission layer (EML). A first TFT that is one of the plurality of TFTs includes a first active

pattern including a channel region, a lightly doped region, and a heavily doped region, and a first lower conductive pattern disposed on the first active pattern and covering the channel region. The capacitor includes the first lower conductive pattern, and a first upper conductive pattern that is disposed on the first lower conductive pattern and that covers the channel region and the lightly doped region.

[0020] A boundary between the lightly doped region and the heavily doped region may be positioned in correspondence to an edge of the first upper conductive pattern. A boundary between the channel region and the lightly doped region may be positioned in correspondence to an edge of the first lower conductive pattern.

[0021] The first lower conductive pattern may function as a gate electrode of the first TFT and a lower electrode of the capacitor.

[0022] The heavily doped region may include a source region and a drain region which are disposed at sides of the channel region. Also, the lightly doped region may include a low-density source region between the channel region and the source region, and a low-density drain region between the channel region and the drain region.

[0023] The first TFT may be a driving TFT that supplies driving current to the EML.

[0024] A second TFT that is one of the plurality of TFTs may include a second active pattern that is formed from the same layer as the first active pattern and that includes a source region, a drain region, and a channel region between the source region and the drain region, and a second lower conductive pattern that is formed from the same layer as the first lower conductive pattern, that covers the channel region of the second active pattern, and that functions as a gate electrode of the second TFT.

[0025] The second active pattern may further include a lightly doped region between the channel region and one of the source region and the drain region. The organic light-emitting display device may include a second upper conductive pattern formed from the same layer as the first upper conductive pattern and covering the channel region and the lightly doped region of the second active pattern.

[0026] According to another aspect of the present invention, there is provided a method of manufacturing a thin film semiconductor device, the method including operations of forming an active pattern on a substrate, forming a lower conductive pattern on the active pattern, lightly injecting impurities into the active pattern by using the lower conductive pattern as a doping mask, forming an upper conductive pattern on the lower conductive pattern, and heavily injecting impurities into the active pattern by using the lower conductive pattern and the upper conductive pattern as doping masks, thus forming the active pattern including a channel region, a lightly doped region, and a heavily doped region.

[0027] The lower conductive pattern may cover the channel region and may not cover the lightly doped region and the heavily doped region. Also, the upper conductive pattern may cover the channel region and the lightly doped region, and may not cover the heavily doped region.

[0028] The operation of forming the lower conductive pattern may include operations of forming a lower gate insulating layer on the active pattern, and forming the lower conductive pattern on the lower gate insulating layer. Also, the operation of forming the upper conductive pattern may include operations of forming an upper gate insulating layer

on the lower conductive pattern, and forming the upper conductive pattern on the upper gate insulating layer.

[0029] The active pattern and the lower conductive pattern may configure a thin film transistor (TFT). The lower conductive pattern and the upper conductive pattern may configure a capacitor. The lower conductive pattern may function as a gate electrode of the TFT and a lower electrode of the capacitor.

BRIEF DESCRIPTION OF THE DRAWINGS

[0030] The above and other features and advantages of the present invention will become more apparent by describing in detail exemplary embodiments thereof with reference to the attached drawings in which:

[0031] FIG. 1 is a cross-sectional view illustrating a thin film semiconductor device constructed as an embodiment according to the principles of the present invention;

[0032] FIGS. 2A through 2C are cross-sectional views showing a method of manufacturing the thin film semiconductor device of FIG. 1, according to an embodiment of the present invention;

[0033] FIG. 3A is a cross-sectional view of a thin film semiconductor device constructed as another embodiment according to the principles of the present invention;

[0034] FIG. 3B is a cross-sectional view of a thin film semiconductor device constructed as another embodiment according to the principles of the present invention;

[0035] FIG. 4 is an equivalent circuit diagram illustrating one pixel of an organic light-emitting display device, according to an embodiment of the present invention;

[0036] FIG. 5 is a plane view illustrating a pixel of the organic light-emitting display device shown in FIG. 4; and

[0037] FIG. 6 is a cross-sectional view illustrating the organic light-emitting display device of FIG. 5, taken along line VI-VI.

DETAILED DESCRIPTION OF THE INVENTION

[0038] The present invention will now be described more fully with reference to the accompanying drawings, in which exemplary embodiments of the invention are shown. The invention may, however, be embodied in many different forms, and should not be construed as being limited to the embodiments set forth herein. Thus, the invention may include all revisions, equivalents, or substitutions which are included in the concept and the technical scope related to the invention.

[0039] Like reference numerals in the drawings denote like elements. In the drawings, the dimension of structures may be exaggerated for clarity.

[0040] Furthermore, all examples and conditional language recited herein are to be construed as being without limitation to such specifically recited examples and conditions. Throughout the specification, a singular form may include plural forms, unless there is a particular description contrary thereto. Also, terms such as "comprise" or "comprising" are used to specify existence of a recited form, a number, a process, an operation, a component, and/or groups thereof, not excluding the existence of one or more other recited forms, one or more other numbers, one or more other processes, one or more other operations, one or more other components and/or groups thereof. As used herein, the term "and/or" includes any and all combinations of one or more of the associated listed items. Throughout the specification, while

terms “first” and “second” are used to describe various components, it is obvious that the components are not limited to the terms “first” and “second”. The terms “first” and “second” are used only to distinguish between each component. As used herein, it will also be understood that when a first feature is referred to as being “connected to”, “combined with”, or “interfaced with” a second feature, intervening third features may also be present. Also, throughout the specification, it will also be understood that when an element such as layer, region, or substrate is referred to as being “on”, “connected to” or “coupled with” another element, it can be directly on the other element, or intervening elements may also be present. However, when an element is referred to as being “directly on”, “directly connected to” or “directly coupled with” another element, it will be understood that there are no intervening elements.

[0041] Unless expressly described otherwise, all terms including descriptive or technical terms which are used herein should be construed as having meanings that are obvious to one of ordinary skill in the art. Also, terms that are defined in a general dictionary and that are used in the following description should be construed as having meanings that are equivalent to meanings used in the related description, and unless expressly described otherwise herein, the terms should not be construed as being ideal or excessively formal.

[0042] FIG. 1 is a cross-sectional view illustrating a thin film semiconductor device 100 constructed as an embodiment according to the principles of the present invention.

[0043] Referring to FIG. 1, the thin film semiconductor device 100 includes a substrate 110 and a first thin film transistor (TFT) TFTa on the substrate 110. The thin film semiconductor device 100 may further include a capacitor Cst on the first TFT TFTa. The thin film semiconductor device 100 may further include a second TFT TFTb. The thin film semiconductor device 100 indicates all devices that include the first TFT TFTa. For example, the thin film semiconductor device 100 may be a flat panel display device such as an organic light-emitting display device, a liquid crystal display device, or the like.

[0044] The substrate 110 may be an insulating substrate formed of a transparent glass material containing SiO₂ as a main constituent or a transparent plastic material. The substrate 110 may be a conductive substrate formed of a thin film metal material. The substrate 110 may be a flexible substrate or a rigid substrate.

[0045] A buffer layer 115 may be disposed on the substrate 110 so as to prevent diffusion of impurity ions or penetration of exterior air and to provide a planarized surface. The first and second TFTs TFTa and TFTb may be disposed on the buffer layer 115.

[0046] The first TFT TFTa includes a first active pattern 121 in which a channel is formed, a first lower conductive pattern 131 to which an electric field is applied to allow the channel to be formed, and a lower gate insulating layer 127 that is interposed between the first active pattern 121 and the first lower conductive pattern 131.

[0047] The first active pattern 121 includes a channel region 121c in which the channel is formed, and a source region 121s and a drain region 121d that are respectively disposed at opposite sides of the channel region 121c. The first active pattern 121 further includes a low-density source region 121ls between the channel region 121c and the source region 121s, and a low-density drain region 121ld between the channel region 121c and the drain region 121d. A channel

length of the channel region 121c that is defined by the low-density source region 121ls and the low-density drain region 121ld may be a first length l1, and a length of the low-density source region 121ls, the channel region 121c, and the low-density drain region 121ld that are defined by the source region 121s and the drain region 121d may be a second length l2.

[0048] The low-density source region 121ls and the low-density drain region 121ld have a doping density that is lower than an impurity doping density of the source region 121s and the drain region 121d. In this regard, the low-density source region 121ls and the low-density drain region 121ld may be collectively referred to as a lightly doped region. Also, since the source region 121s and the drain region 121d have an impurity doping density higher than the doping density of the lightly doped region, the source region 121s and the drain region 121d may be collectively referred to as a heavily doped region.

[0049] In the embodiment of FIG. 1, the low-density source region 121ls and the low-density drain region 121ld are disposed between the channel region 121c and the source region 121s and between the channel region 121c and the drain region 121d, respectively; however, in other embodiments of the present invention, only one of the low-density source region 121ls and the low-density drain region 121ld may be arranged. For example, the low-density source region 121ls may be omitted and only the low-density drain region 121ld may be disposed.

[0050] The first lower conductive pattern 131 may function as a gate electrode of the first TFT TFTa. A width of the first lower conductive pattern 131 in a channel length direction may correspond to the first length l1 that is the channel length of the channel region 121c. Both edges of the first lower conductive pattern 131 in the channel length direction may define the channel length of the channel region 121c. That is, a boundary between the low-density source region 121ls and the channel region 121c, and a boundary between the low-density drain region 121ld and the channel region 121c may be defined by the edges of the first lower conductive pattern 131.

[0051] A first upper conductive pattern 141 may be disposed on the first lower conductive pattern 131. An upper gate insulating layer 137 may be disposed between the first lower conductive pattern 131 and the first upper conductive pattern 141. The first upper conductive pattern 141 and the first lower conductive pattern 131 may configure the capacitor Cst. The upper gate insulating layer 137 may function as a dielectric layer of the capacitor Cst, and the first upper conductive pattern 141 and the first lower conductive pattern 131 may function as an upper electrode and a lower electrode of the capacitor Cst, respectively. As described above, the first lower conductive pattern 131 may simultaneously function as the lower electrode of the capacitor Cst and the gate electrode of the first TFT TFTa.

[0052] As illustrated in FIG. 1, the first upper conductive pattern 141 may have a width l2 that is greater than the width of the first lower conductive pattern 131. The first upper conductive pattern 141 may define the boundary between the low-density source region 121ls and the source region 121s, and the boundary between the low-density drain region 121ld and the drain region 121d. That is, the second length l2 that is the length of the low-density source region 121ls, the channel region 121c, and the low-density drain region 121ld in the

channel length direction may be defined by the width **12** of the first upper conductive pattern **141**.

[0053] The second TFT **TFTb** includes a second active pattern **123** in which a channel is formed, a second lower conductive pattern **133** to which an electric field is applied to allow the channel to be formed, and the lower gate insulating layer **127** that is interposed between the second active pattern **123** and the second lower conductive pattern **133**. The second active pattern **123** may be formed from the same material layer as the first active pattern **121**. Also, the second lower conductive pattern **133** may be formed from the same material layer as the first lower conductive pattern **131**.

[0054] The second active pattern **123** includes a channel region **123c** in which the channel is formed, and a source region **123s** and a drain region **123d** that are respectively disposed at opposite sides of the channel region **123c**. The second lower conductive pattern **133** may be disposed on the channel region **123c**. A channel length of the channel region **123c** that is defined by the source region **123s** and the drain region **123d** may be determined by a width of the second lower conductive pattern **133**. The second lower conductive pattern **133** may function as a gate electrode of the second TFT **TFTb**.

[0055] An interlayer insulating layer **147** may be disposed on the upper gate insulating layer **137** and the first upper conductive pattern **141**. Although not illustrated in FIG. 1, electrode patterns that function as wires may be disposed on the interlayer insulating layer **147**, and may be electrically connected to the first and second TFTs **TFTa** and **TFTb** and the capacitor **Cst** via contact plugs that penetrate through the interlayer insulating layer **147**. The electrode patterns may be the wires that are connected to a source electrode that is connected to the source regions **121s** and **123s**; a drain electrode that is connected to the drain electrodes **121d** and **123d**; a gate wire that is connected to the first and second lower conductive patterns **131** and **133**; and a wire that is connected to the first upper conductive pattern **141**.

[0056] Although not illustrated in FIG. 1, the thin film semiconductor device **100** may further include a TFT that uses both the lower gate insulating layer **127** and the upper gate insulating layer **137** as a gate insulating layer. The TFT may include an active pattern formed from the same layer as the first and second active patterns **121** and **123**, and a gate electrode formed from the same layer as the first upper conductive pattern **141**. Here, only the lower gate insulating layer **127** and the upper gate insulating layer **137** may be disposed between the active pattern and the gate electrode. A channel of the TFT is formed by applying a higher voltage to the gate electrode, compared to the first and second TFTs **TFTa** and **TFTb** that use only the lower gate insulating layer **127** as a gate insulating layer, so that the TFT is advantageous in its broad operational range.

[0057] FIGS. 2A through 2C are cross-sectional views showing a method of manufacturing the thin film semiconductor device **100** of FIG. 1, according to an embodiment of the present invention.

[0058] Referring to FIG. 2A, the substrate **110**, the buffer layer **115** on the substrate **110**, and the first and second active patterns **121** and **123** on the buffer layer **115** are arranged.

[0059] The substrate **110** may be formed of a transparent glass material containing SiO₂ as a main constituent. However, a material of the substrate **110** is not limited thereto and thus the substrate **110** may be formed of a transparent plastic material. Here, the transparent plastic material that forms the

substrate **110** may include one or more materials selected from among various organic materials.

[0060] The buffer layer **115** may be formed on the substrate **110**. The buffer layer **115** may include an inorganic insulating material such as silicon oxide, silicon nitride, silicon oxynitride, aluminum oxide, aluminum nitride, titanium oxide, or titanium nitride. The buffer layer **115** may include an organic insulating material such as polyimide, polyester, acryl, or the like and may be formed as a stack including the aforementioned materials or including the organic insulating material and the inorganic insulating material. Since the buffer layer **115** is not an essential element, the buffer layer **115** may be omitted according to a process condition.

[0061] The first and second active patterns **121** and **123** may be formed on the buffer layer **115**. In more detail, a semiconductor material layer (not shown), e.g., an amorphous silicon layer, is first deposited on the buffer layer **115** and then is crystallized into a polysilicon layer (not shown). The amorphous silicon may be crystallized by using various methods including a rapid thermal annealing (RTA) method, a solid phase crystallization (SPC) method, an excimer laser annealing (ELA) method, a metal-induced crystallization (MIC) method, a metal-induced lateral crystallization (MILC) method, a sequential lateral solidification (SLS) method, and the like. The polysilicon layer may be patterned into the first and second active patterns **121** and **123** via a photolithography process using a first mask (not shown).

[0062] Referring to FIG. 2A, the first and second active patterns **121** and **123** are separated from each other. However, portions of the first and second active patterns **121** and **123**, which are not shown in FIG. 2A, may be connected to each other. Also, in another embodiment, the first and second active patterns **121** and **123** that are formed of polysilicon may be formed in a manner that an amorphous silicon layer is first patterned and then is crystallized.

[0063] The first and second active patterns **121** and **123** may be formed as a silicon-based element semiconductor, but in other embodiments, the first and second active patterns **121** and **123** may be formed as a compound semiconductor, e.g., an oxide semiconductor or an organic semiconductor.

[0064] FIG. 2B illustrates the lower gate insulating layer **127** that covers the first and second active patterns **121** and **123**, and the first and second lower conductive patterns **131** and **133**. The first and second active patterns **121** and **123** may be divided into the channel regions **121c** and **123c** and lightly doped regions **121l** and **123l**, respectively.

[0065] The lower gate insulating layer **127** may be formed on the buffer layer **115** so as to cover the first and second active patterns **121** and **123**. The lower gate insulating layer **127** may be formed of oxide, nitride, oxynitride, or a composition thereof.

[0066] The first and second lower conductive patterns **131** and **133**, which overlap with the channel regions **121c** and **123c** of the first and second active patterns **121** and **123**, respectively, may be formed on the lower gate insulating layer **127**. In more detail, a first conductive layer (not shown) may be stacked on the lower gate insulating layer **127** and then may be patterned into the first and second lower conductive patterns **131** and **133** via a photolithography process and an etching process which use a second mask (not shown).

[0067] An ion implantation process may be performed by using the first and second lower conductive patterns **131** and **133** as a doping mask. Impurity ions with low density may be injected into portions of the first and second active patterns

121 and **123** that are not covered by the first and second lower conductive patterns **131** and **133**. As a result, the lightly doped regions **121^l** and **123^l** are formed on the portions of the first and second active patterns **121** and **123** which are not covered by the first and second lower conductive patterns **131** and **133**, and the channel regions **121^c** and **123^c**, to which the impurity ions are not injected, are formed on portions of the first and second active patterns **121** and **123** that are covered by the first and second lower conductive patterns **131** and **133**.

[0068] FIG. 2C illustrates the upper gate insulating layer **137** that covers the first and second lower conductive patterns **131** and **133**, and the first upper conductive pattern **141**. The first active pattern **121** may be divided into the channel region **121^c** and the lightly doped regions **121^l**.

[0069] The upper gate insulating layer **137** may be formed on the lower gate insulating layer **127** so as to cover the first and second lower conductive patterns **131** and **133**. The upper gate insulating layer **137** may be formed of oxide, nitride, oxynitride, or a composition thereof. The upper gate insulating layer **137** may be formed of the same material as the lower gate insulating layer **127**, but in another embodiment, the upper gate insulating layer **137** may be formed of a different material from the lower gate insulating layer **127**.

[0070] The first upper conductive pattern **141** that overlaps with the channel region **121^c** and the lightly doped regions **121^l** of the first active pattern **121** may be formed on the upper gate insulating layer **137**. In more detail, a second conductive layer (not shown) may be stacked on the upper gate insulating layer **137** and may be patterned into the first upper conductive pattern **141** via a photolithography process and an etching process which use a third mask (not shown).

[0071] An ion implantation process may be performed by using the first and second lower conductive patterns **131** and **133** and the first upper conductive pattern **141** as doping masks. Impurity ions with high density may be injected into portions of the first and second active patterns **121** and **123** which are not covered by the first and second lower conductive patterns **131** and **133** and the first upper conductive pattern **141**. As a result, portions of the first and second active patterns **121** and **123** that are covered by the first and second lower conductive patterns **131** and **133** are formed as the channel regions **121^c** and **123^c**; portions of the first and second active patterns **121** and **123** that are not covered by the first and second lower conductive patterns **131** and **133** but are covered by the first upper conductive pattern **141** are formed as the lightly doped regions **121^l**; and portions of the first and second active patterns **121** and **123** that are not covered by the first and second lower conductive patterns **131** and **133** and the first upper conductive pattern **141** are formed as heavily doped regions **121^h** and **123^h**.

[0072] Referring back to FIG. 1, the heavily doped regions **121^h** of the first active pattern **121** become the source region **121^s** and the drain region **121^d**, and the lightly doped regions **121^l** of the first active pattern **121** become the low-density source region **121^{ls}** and the low-density drain region **121^{ld}**. Similarly, the heavily doped regions **123^h** of the second active pattern **123** become the source region **123^s** and the drain region **123^d**.

[0073] Afterward, the interlayer insulating layer **147** of FIG. 1 may be formed on the upper gate insulating layer **137** so as to cover the first upper conductive pattern **141**.

[0074] FIG. 3A is a cross-sectional view of a thin film semiconductor device **100a** constructed as another embodiment according to the principles of the present invention.

[0075] Referring to FIG. 3A, the thin film semiconductor device **100a** may include not only a first TFT **TFTa** and a capacitor **Cst** on the first TFT **TFTa** but may also include a third TFT **TFTc**. The thin film semiconductor device **100a** is substantially the same as the thin film semiconductor device **100** of FIG. 1 except that the thin film semiconductor device **100a** includes the third TFT **TFTc**. Thus, the present embodiment will be described in terms of features different from those of the previous embodiment. Referring to FIG. 3A, the third TFT **TFTc** replaces the second TFT **TFTb** of FIG. 1. However, the present embodiment is not limited thereto and thus the thin film semiconductor device **100a** may include both the second TFT **TFTb** and the third TFT **TFTc**.

[0076] The third TFT **TFTc** includes a third active pattern **125** in which a channel is formed, a third lower conductive pattern **135** that functions as a gate electrode of the third TFT **TFTc**, and the lower gate insulating layer **127** that is interposed between the third active pattern **125** and the third lower conductive pattern **135**.

[0077] Similar to the first active pattern **121**, the third active pattern **125** may include a source region **125^s**, a low-density source region **125^{ls}**, a channel region **125^c**, a low-density drain region **125^{ld}**, and a drain region **125^d**, which are sequentially formed. Referring to FIG. 3A, the low-density source region **125^{ls}** and the low-density drain region **125^{ld}** are disposed between the channel region **125^c** and the source region **125^s** and between the channel region **125^c** and the drain region **125^d**, respectively. However, according to other embodiments of the present invention, only one of the low-density source region **125^{ls}** and the low-density drain region **125^{ld}** may be disposed. For example, only the low-density drain region **125^{ld}** may be disposed, and the source region **125^s** may be disposed adjacent to the channel region **125^c** instead of the low-density source region **125^{ls}**.

[0078] The third lower conductive pattern **135**, the upper gate insulating layer **137**, and a second upper conductive pattern **145a** may be sequentially stacked on the third active pattern **125**. At least one portion of the third lower conductive pattern **135** may overlap with the channel region **125^c** of the third active pattern **125**. The third lower conductive pattern **135** does not overlap with the source region **125^s**, the low-density source region **125^{ls}**, the low-density drain region **125^{ld}**, and the drain region **125^d** of the third active pattern **125**.

[0079] At least one portion of the second upper conductive pattern **145a** may overlap with the low-density source region **125^{ls}**, the channel region **125^c**, and the low-density drain region **125^{ld}** of the third active pattern **125**. The second upper conductive pattern **145a** does not overlap with the source region **125^s** and the drain region **125^d** of the third active pattern **125**.

[0080] Thus, a boundary between the low-density source region **125^{ls}** and the channel region **125^c**, and a boundary between the channel region **125^c** and the low-density drain region **125^{ld}** are defined in correspondence to edges of the third lower conductive pattern **135**. Also, a boundary between the source region **125^s** and the low-density source region **125^{ls}**, and a boundary between the low-density drain region **125^{ld}** and the drain region **125^d** are defined in correspondence to edges of the second upper conductive pattern **145a**.

[0081] The third lower conductive pattern **135** and the second upper conductive pattern **145a** may also configure a capacitor. However, unless there is a demand for a circuit configuration in which a gate electrode of the third TFT **TFTc**

is connected to the capacitor, the capacitance formed between the third lower conductive pattern 135 and the second upper conductive pattern 145a may exist as a parasitic capacitance that causes a delay. In order to prevent this problem, the second upper conductive pattern 145a may be directly and electrically connected to the third lower conductive pattern 135, thereby functioning as a common gate electrode of the third TFT TFTc. In another embodiment, the second upper conductive pattern 145a may float so as to decrease the parasitic capacitance that is formed between the third lower conductive pattern 135 and the second upper conductive pattern 145a.

[0082] FIG. 3B is a cross-sectional view of a thin film semiconductor device 100b constructed as another embodiment according to the principles of the present invention.

[0083] Referring to FIG. 3B, the thin film semiconductor device 100b may include not only the first TFT TFTa, the capacitor Cst, and the third TFT TFTc but may also include a third upper conductive pattern 145b on the third TFT TFTc. Except that the thin film semiconductor device 100b includes the third upper conductive pattern 145b, instead of the second upper conductive pattern 145a, the thin film semiconductor device 100b is substantially the same as the thin film semiconductor device 100a of FIG. 3A. Thus, the present embodiment will be described in terms of features different from those of the previous embodiment.

[0084] The third upper conductive pattern 145b overlaps with the low-density source region 125s and the low-density drain region 125d of the third active pattern. The third upper conductive pattern 145b does not overlap with the source region 125s and the drain region 125d of the third active pattern 125. The third upper conductive pattern 145b may not overlap with the channel region 125c of the third active pattern 125. In another embodiment, the third upper conductive pattern 145b may partially overlap with the channel region 125c of the third active pattern 125.

[0085] Since the third upper conductive pattern 145b does not overlap with the third lower conductive pattern 135, the parasitic capacitance between the third lower conductive pattern 135 and the second upper conductive pattern 145a may be minimized.

[0086] FIG. 4 is an equivalent circuit diagram illustrating one pixel of an organic light-emitting display device, according to an embodiment of the present invention.

[0087] As illustrated in FIG. 4, one pixel of the organic light-emitting display device includes a plurality of signal lines 12, 14, 16, 32, 34, and 42, and a pixel circuit that is connected to the plurality of signal lines 12, 14, 16, 32, 34, and 42 and that includes a plurality of TFTs T1, T2, T3, T4, T5, and T6, and a storage capacitor Cst. Also, the pixel includes an organic light-emitting diode (OLED) that receives driving current via the pixel circuit and thus emits light.

[0088] The plurality of TFTs T1, T2, T3, T4, T5, and T6 may include a driving TFT T1, a switching TFT T2, a compensation TFT T3, an initialization TFT T4, an operation control TFT T5, and an emission control TFT T6.

[0089] The plurality of signal lines 12, 14, 16, 32, 34, and 42 may include a previous scan line 12 for transmitting a previous scan signal Sn-1 to the initialization TFT T4, a scan line 14 for transmitting a scan signal Sn, an emission control line 16 for transmitting an emission control signal En to the operation control TFT T5 and the emission control TFT T6, a data line 32 crossing the scan line 14 and for transmitting a

data signal Dm, a driving voltage line 34 for transmitting a driving voltage ELVDD and extending in parallel with the data line 32, and an initialization voltage line 42 for transmitting an initialization voltage Vint to initialize the driving TFT T1.

[0090] A gate G1 of the driving TFT T1 is connected to an electrode Cst1 of the storage capacitor Cst. A source S1 of the driving TFT T1 is connected to the driving voltage line 34 via the operation control TFT T5. A drain D1 of the driving TFT T1 is electrically connected to an anode of the OLED via the emission control TFT T6. The driving TFT T1 receives the data signal Dm according to a switching operation of the switching TFT T2 and supplies driving current Id to the OLED.

[0091] A gate G2 of the switching TFT T2 is connected to the scan line 14, and a source S2 of the switching TFT T2 is connected to the data line 32. A drain D2 of the switching TFT T2 is connected to the source S1 of the driving TFT T1 and to the driving voltage line 34 via the operation control TFT T5. The switching TFT T2 is turned on in response to the scan signal Sn that is transmitted via the scan line 14, and then transmits the data signal Dm, which is transmitted via the data line 32, to the source S1 of the driving TFT T1.

[0092] A gate G3 of the compensation TFT T3 is connected to the scan line 14. A source S3 of the compensation TFT T3 is connected to the drain D1 of the driving TFT T1 and to the anode of the OLED via the emission control TFT T6. A drain D3 of the compensation TFT T3 is commonly connected to the electrode Cst1 of the storage capacitor Cst, a drain D4 of the initialization TFT T4, and the gate G1 of the driving TFT T1. The compensation TFT T3 is turned on in response to the scan signal Sn that is transmitted via the scan line 14, and then diode-connects the driving TFT T1 by connecting the gate G1 and the drain D1 of the driving TFT T1.

[0093] A gate G4 of the initialization TFT T4 is connected to the previous scan line 12, and a source S4 of the initialization TFT T4 is connected to the initialization voltage line 42. The drain D4 of the initialization TFT T4 is commonly connected to the electrode Cst1 of the storage capacitor Cst, the drain D3 of the compensation TFT T3, and the gate G1 of the driving TFT T1. The initialization TFT T4 performs an initialization operation in which the initialization TFT T4 is turned on in response to the previous scan signal Sn-1 that is transmitted via the previous scan line 12, and then transmits the initialization voltage Vint to the gate G1 of the driving TFT T1 and thus initializes a voltage of the gate G1 of the driving TFT T1.

[0094] A gate G5 of the operation control TFT T5 is connected to the emission control line 16, a source S5 of the operation control TFT T5 is connected to the driving voltage line 34, and a drain D5 of the operation control TFT T5 is commonly connected to the source S1 of the driving TFT T1 and the drain D2 of the switching TFT T2.

[0095] A gate G6 of the emission control TFT T6 is connected to the emission control line 16, and a source S6 of the emission control TFT T6 is commonly connected to the drain D1 of the driving TFT T1 and the source S3 of the compensation TFT T3. A drain D6 of the emission control TFT T6 is connected to the anode of the OLED. The operation control TFT T5 and the emission control TFT T6 are simultaneously turned on in response to the emission control signal En that is transmitted via the emission control line 16, so that the driving current Id flows in the OLED.

[0096] The other electrode Cst2 of the storage capacitor Cst is connected to the driving voltage line 34. The electrode Cst1 of the storage capacitor Cst is commonly connected to the gate G1 of the driving TFT T1, the drain D3 of the compensation TFT T3, and the drain D4 of the initialization TFT T4.

[0097] A common voltage ELVSS is applied to a cathode of the OLED. The OLED emits light by receiving the driving current Id from the driving TFT T1, and thus displays an image.

[0098] Hereinafter, an operation procedure of the pixel of the organic light-emitting display device shown in FIG. 4 will be described in detail.

[0099] First, during an initialization period, the previous scan signal Sn-1 at a low level is supplied via the previous scan line 12. Then, the initialization TFT T4 is turned on in response to the previous scan signal Sn-1 at a low level, the initialization voltage Vint from the initialization voltage line 42 is applied to the gate G1 of the driving TFT T1 via the initialization TFT T4, and the driving TFT T1 is initialized due to the initialization voltage Vint.

[0100] Afterward, the scan signal Sn at a low level is supplied via the scan line 14 during a data programming period. Thus, the switching TFT T2 and the compensation TFT T3 are turned on in response to the scan signal Sn at a low level. Here, the driving TFT T1 is diode-connected due to the turned on compensation TFT T3, and is biased in a forward direction.

[0101] Then, a compensation voltage Dm-Vth, which is obtained by subtracting a threshold Vth of the driving TFT T1 from the data signal Dm that is supplied from the data line 32, is applied to the gate G1 of the driving TFT T1.

[0102] The driving voltage ELVDD and the compensation voltage Dm-Vth are applied to terminals of the storage capacitor Cst, respectively, and charge that corresponds to a voltage difference (i.e., ELVDD-Dm+Vth) between the terminals is stored in the storage capacitor Cst. Afterward, the emission control signal En that is supplied from the emission control line 16 is changed from a high level to a low level during an emission period. Then, the operation control TFT T5 and the emission control TFT T6 are turned on in response to the emission control signal En at a low level during the emission period.

[0103] Then, the driving current Id is generated due to the voltage difference between the voltage of the gate G1 of the driving TFT T1 and the driving voltage ELVDD, and then is supplied to the OLED via the emission control TFT T6. A gate-source voltage Vgs of the driving TFT T1 is maintained at a level of 'ELVDD-Dm+Vth' due to the storage capacitor Cst level during the emission period, and according to a current-voltage relation of the driving TFT T1, the driving current Id is proportional to a square value ((ELVDD-Dm)²) of a value that is obtained by subtracting the threshold voltage Vth from the gate-source voltage Vgs. Thus, the driving current Id is determined regardless of the threshold voltage Vth of the driving TFT T1.

[0104] The first TFT TFTa of FIG. 1 may correspond to the driving TFT T1 of FIG. 4, and the second TFT TFTb of FIG. 1 may correspond to one of the other TFTs T2 through T6. For example, the second TFT TFTb of FIG. 1 may be the switching TFT T2.

[0105] Hereinafter, a structure of the pixel of the organic light-emitting display device shown in FIG. 4 will be described in detail with reference to FIGS. 5 and 6. Here, it is assumed that the driving TFT T1 has a structure of the first TFT TFTa of FIG. 1.

[0106] FIG. 5 is a plane view illustrating a pixel P of the organic light-emitting display device shown in FIG. 4.

[0107] Referring to FIG. 5, the pixel P of the organic light-emitting display device includes a driving TFT T1, a switching TFT T2, a compensation TFT T3, an initialization TFT T4, an operation control TFT T5, an emission control TFT T6, a storage capacitor Cst, and an OLED.

[0108] The pixel P includes a scan line 14, a previous scan line 12, an emission control line 16, an initialization voltage line 42, a data line 32, and a driving voltage line 34 to which a scan signal Sn, a previous scan signal Sn-1, an emission control signal En, an initialization voltage Vint, a data signal Dm, and a driving voltage ELVDD are applied, respectively. The scan line 14, the previous scan line 12, the emission control line 16, and the initialization voltage line 42 extend in a row direction, and the data line 32 and the driving voltage line 34 extend in a column direction.

[0109] The pixel P may include a semiconductor layer Act, a first conductive layer M1, a second conductive layer M2, a third conductive layer M3, and a fourth conductive layer M4. Although not illustrated in FIG. 5, an insulating layer may be interposed between each of the semiconductor layer Act, the first conductive layer M1, the second conductive layer M2, the third conductive layer M3, and the fourth conductive layer M4. Also, the pixel P may further include an intermediate layer (not shown) including an emission layer (EML), and a common electrode layer (not shown).

[0110] The semiconductor layer Act includes active patterns Act1 through Act6 of the driving TFT T1, the switching TFT T2, the compensation TFT T3, the initialization TFT T4, the operation control TFT T5, and the emission control TFT T6, respectively. The driving TFT T1, the switching TFT T2, the compensation TFT T3, the initialization TFT T4, the operation control TFT T5, and the emission control TFT T6 may be disposed along the semiconductor layer Act.

[0111] Referring to FIG. 5, the semiconductor layer Act is formed as one pattern in the pixel P. However, according to a design, the semiconductor layer Act may be formed as at least two separated patterns. The semiconductor layer Act may have various forms according to designs, and may include bent portions as shown in FIG. 5.

[0112] The first conductive layer M1 may include the previous scan line 12, the scan line 14, and the emission control line 16. Also, the first conductive layer M1 may include gate electrodes g1 through g6 of the driving TFT T1, the switching TFT T2, the compensation TFT T3, the initialization TFT T4, the operation control TFT T5, and the emission control TFT T6, respectively.

[0113] The second conductive layer M2 may include an upper electrode Cst2 of the capacitor Cst. The third conductive layer M3 may include the data line 32, the driving voltage line 34, and a connection line 36. The fourth conductive layer M4 may include the initialization voltage line 42 and a pixel electrode 44.

[0114] The semiconductor layer Act may be formed of polysilicon and may include a channel region that is not doped with impurities, and a source region and a drain region that are doped with impurities at sides of the channel region. Also, a driving active pattern Act1 of the driving TFT T1 may include not only a channel region, a source region s1, and a drain region d1 but may also include a low-density source region ls1 between the channel region and the source region s1, and a low-density drain region ld1 between the channel region and the drain region d1.

[0115] Here, impurities may vary according to types of a TFT and may be n-type impurities or p-type impurities. The semiconductor layer Act may include the driving active pattern Act1 of the driving TFT T1, a switching active pattern Act2 of the switching TFT T2, a compensation active pattern Act3 of the compensation TFT T3, an initialization active pattern Act4 of the initialization TFT T4, an operation control active pattern Act5 of the operation control TFT T5, and an emission control active pattern Act6 of the emission control TFT T6.

[0116] The driving TFT T1 includes the driving active pattern Act1 and a driving gate electrode g1. The driving active pattern Act1 may include a channel region that overlaps with the driving gate electrode g1, the source and drain regions s1 and d1, the low-density source region ls1 between the channel region and the source region s1, and the low-density drain region ld1 between the channel region and the drain region d1. The driving gate electrode g1 does not overlap with the low-density source region ls1 and the low-density drain region ld1. The low-density source region ls1 and the low-density drain region ld1 overlap with the upper electrode Cst2 of the capacitor Cst. The source and drain regions s1 and d1 do not overlap with any of the driving gate electrode g1 and the upper electrode Cst2. The driving active pattern Act1 is bent.

[0117] The upper electrode Cst2 is disposed on the driving gate electrode g1. The upper electrode Cst2 includes an opening Cst2op through which a contact plug 36p1 that is connected between the driving gate electrode g1 and the connection line 36 passes. Referring to FIG. 5, a shape of the opening Cst2op is rectangular but the shape of the opening Cst2op is not limited thereto. The upper electrode Cst2 may maximally overlap with the driving gate electrode g1 except for the opening Cst2op, and by doing so, a maximal capacitance may be achieved. As described above, the upper electrode Cst2 covers the low-density source region ls1 and the low-density drain region ld1.

[0118] The upper electrode Cst2 and the driving gate electrode g1 may configure a capacitor Cst. The driving gate electrode g1 also functions as a lower electrode of the capacitor Cst.

[0119] The upper electrode Cst2 may be connected to the driving voltage line 34 via contact plugs 34p1.

[0120] The switching TFT T2 includes the switching active pattern Act2 and a switching gate electrode g2 that is a portion of the scan line 14. The switching active pattern Act2 includes a channel region that overlaps with the switching gate electrode g2, and a source region s2 and a drain region d2 at sides of the channel region. The source region s2 may be connected to the data line 32 via a contact plug 34p1. The drain region d2 is connected to the source region s1 of the driving TFT T1 along the semiconductor layer Act.

[0121] The compensation TFT T3 includes the compensation active pattern Act3 and a compensation gate electrode g3 that is a portion of the scan line 14. The compensation active pattern Act3 includes a channel region that overlaps with the compensation gate electrode g3, and a source region s3 and a drain region d3 that are at sides of the channel region. The source region s3 is connected to the drain region d1 of the driving TFT T1 along the semiconductor layer Act. The drain region d3 may be connected to the connection line 36 via a contact plug 36p2. That is, the drain region d3 of the compensation TFT T3 is electrically connected to the driving gate electrode g1 via the connection line 36. As illustrated in FIG.

5, the compensation gate electrode g3 is formed as separate dual gate electrodes, so that leakage current may be prevented.

[0122] The initialization TFT T4 may include the initialization active pattern Act4 and an initialization gate electrode g4 that is a portion of the previous scan line 12. The initialization active pattern Act4 includes a channel region that overlaps with the initialization gate electrode g4, and a source region s4 and a drain region d4 that are at sides of the channel region. The source region s4 is connected to the initialization voltage line 42 via a contact plug 42p. Although not illustrated, the contact plug 42p may include a connection member that is formed of the third conductive layer M3, a contact plug that connects the connection member and the source region s4, and a contact plug that connects the connection member and the initialization voltage line 42. The drain region d4 is connected to the connection line 36 via the contact plug 36p2. As illustrated in FIG. 5, the initialization gate electrode g4 may be formed as separate dual gate electrodes.

[0123] The operation control TFT T5 includes the operation control active pattern Act5 and an operation control gate electrode g5 that is a portion of the emission control line 16. The operation control active pattern Act5 includes a channel region that overlaps with the operation control gate electrode g5, and a source region s5 and a drain region d5 that are at sides of the channel region. The drain region d5 is connected to the source region S1 of the driving TFT T1 along the semiconductor layer Act. The source region s5 is connected to the driving voltage line 34 via a contact plug 34p2.

[0124] The emission control TFT T6 includes the emission control active pattern Act6 and an emission control gate electrode g6 that is a portion of the emission control line 16. The emission control active pattern Act6 includes a channel region that overlaps with the emission control gate electrode g6, and a source region s6 and a drain region d6 that are at sides of the channel region. The source region s6 is connected to the drain electrode D1 of the driving TFT T1 along the semiconductor layer Act. The drain region d6 is connected to the pixel electrode 44 via a contact plug 44p. Although not illustrated, the contact plug 44p may include a connection member that is formed of the third conductive layer M3, a contact plug that connects the connection member and the drain region d6, and a contact plug that connects the connection member and the pixel electrode 44.

[0125] The pixel electrode 44 may be disposed on the upper electrode Cst2 and may apply current to the intermediate layer that includes the EML and that is disposed thereon. The current that is applied to the intermediate layer is transmitted to a common electrode (not shown) on the intermediate layer.

[0126] The circuit diagram of FIG. 4 and the plane view of FIG. 5 may vary according to designs.

[0127] FIG. 6 is a cross-sectional view illustrating the organic light-emitting display device of FIG. 5, taken along line VI-VI.

[0128] Referring to FIG. 6, the organic light-emitting display device (hereinafter, an organic light-emitting display device 200) includes the driving TFT T1, the storage capacitor Cst, the emission control TFT T6, the pixel electrode 44, an intermediate layer 51, and a common electrode 61.

[0129] The driving TFT T1 and the emission control TFT T6 are disposed on a substrate 210. A buffer layer 215 may be disposed on the substrate 210. The upper electrode Cst2 is disposed on the driving TFT T1, and the driving gate elec-

trode **g1** and the upper electrode **Cst2** configure the storage capacitor **Cst**. A lower gate insulating layer **227** is interposed between the driving active pattern **Act1** and the driving gate electrode **g1** and between the emission control active pattern **Act6** and the emission control gate electrode **g6**, and an upper gate insulating layer **237** is interposed between the driving gate electrode **g1** and the upper electrode **Cst2**. The driving TFT **T1**, the storage capacitor **Cst**, and the emission control TFT **T6** are covered by an interlayer insulating layer **247**.

[0130] The driving TFT **T1** may correspond to the first TFT **TFTa** of FIG. 1, and the emission control TFT **T6** may correspond to the second TFT **TFTb** of FIG. 1. The storage capacitor **Cst** corresponds to the capacitor **Cst** of FIG. 1. The lower gate insulating layer **227**, the upper gate insulating layer **237**, and the interlayer insulating layer **247** correspond to the lower gate insulating layer **127**, the upper gate insulating layer **137**, and the interlayer insulating layer **147** of FIG. 1, respectively. Since the driving TFT **T1**, the storage capacitor **Cst**, the emission control TFT **T6**, the lower gate insulating layer **227**, the upper gate insulating layer **237**, and the interlayer insulating layer **247** are described above with reference to FIG. 1, the detailed descriptions thereof are omitted here.

[0131] The driving voltage line **34**, the connection line **36**, and a connection member **38** are disposed above the upper gate insulating layer **237**. The upper electrode **Cst2** is connected to the driving voltage line **34** via contact plugs **34p1**. A total number of the contact plugs **34p1** may vary.

[0132] The driving gate electrode **g1** is connected to the connection line **36** via a contact plug **36p1**. Also, the drain region **d6** of the emission control TFT **T6** is connected to the connection member **38** via a contact plug **38p1** that penetrates through all of the lower gate insulating layer **227**, the upper gate insulating layer **237**, and the interlayer insulating layer **247**.

[0133] A planarization layer **257** is disposed to cover the driving voltage line **34**, the connection line **36**, and the connection member **38** above the upper gate insulating layer **237**. The planarization layer **257** may be formed of an inorganic insulating material including oxide, nitride, and/or oxynitride or may be formed of an organic insulating material.

[0134] The pixel electrode **44** is disposed on the planarization layer **257**. The pixel electrode **44** is connected to the connection member **38** via a contact plug **38p2** that penetrates through the planarization layer **257**. The contact plug **44p** of FIG. 5 indicates a concept including the contact plug **38p1** that is connected between the drain region **d6** and the pixel electrode **44**, the connection member **38**, and the contact plug **38p2**.

[0135] The pixel electrode **44** may be a transparent electrode or a reflective electrode. When the pixel electrode **44** is formed as a transparent electrode, the pixel electrode **44** may include ITO, IZO, ZnO, or In₂O₃. Also, when the pixel electrode **44** is formed as a reflective electrode, the pixel electrode **44** may have a multi-stack structure including a first layer that is formed of Ag, Mg, Al, Pt, Pd, Au, Ni, Nd, Ir, Cr, or compound of any of these, and a second layer that is formed on the first layer and that includes ITO, IZO, ZnO, or In₂O₃.

[0136] A pixel-defining layer (PDL) **267** that defines a pixel by exposing a portion of the pixel electrode **44** may be disposed on the planarization layer **257**. The intermediate layer **51**, including an EML, may be formed on the portion the pixel electrode **44** that is exposed through PDL **267**.

[0137] The common electrode **61** may be stacked on an entire surface of the substrate **210**. Here, the common elec-

trode **61** may be formed as a transparent electrode or a reflective electrode. When the common electrode **61** is formed as a transparent electrode, the common electrode **61** may include a first layer that is formed of Li, Ca, LiF/Ca, LiF/Al, Al, Mg, or a compound of any of these, and a second layer that is formed on the first layer and that includes ITO, IZO, ZnO, or In₂O₃. Here, the second layer may be formed as an auxiliary electrode or a bus electrode line. When the common electrode **61** is formed as a reflective electrode, the aforementioned Li, Ca, LiF/Ca, LiF/Al, Al, Mg, or a compound of any of these is completely deposited.

[0138] The intermediate layer **51** that is interposed between the pixel electrode **44** and the common electrode **61** may include a small molecule organic material or a polymer organic material.

[0139] When the intermediate layer **51** includes a small molecule organic material, the intermediate layer **51** may have a structure in which a hole injection layer (HIL), a hole transport layer (HTL), an EML, an electron transport layer (ETL), and an electron injection layer (EIL) are singularly or multiply stacked.

[0140] Also, the intermediate layer **51** may be formed of various organic materials including copper phthalocyanine (CuPc), N,N'-Di(naphthalene-1-yl)-N,N'-diphenyl-benzidine (NPB), tris-8-hydroxyquinoline aluminum (Alq₃), or the like, by a vacuum deposition method using masks.

[0141] When the intermediate layer **51** includes a polymer organic material, the intermediate layer **51** may have a structure of an HTL and an EML, and in this regard, the HTL may be formed of poly(3,4-ethylenedioxythiophene) (PEDOT), and the EML may be formed of a poly-phenylenevinylene (PPV)-based material or a polyfluorene-based material.

[0142] The EML may emit light in a color selected from a red color, a green color, and a blue color. In another embodiment, the EML may emit white light, and the organic light-emitting display device **200** may further include a color filter layer of a red color, a green color, and a blue color so as to output images with various colors.

[0143] Although not illustrated, an encapsulation layer (not shown) may be formed on the common electrode **61**. The encapsulation layer may have a structure in which a plurality of inorganic layers are stacked or an inorganic layer and an inorganic layer are alternatively stacked.

[0144] In another embodiment, an encapsulation substrate (not shown) may be disposed on the common electrode **61**. The substrate **210** may be encapsulated by the encapsulation substrate.

[0145] According to the one or more embodiments of the present invention, a lightly doped region is interposed between a channel region and a heavily doped region of a thin film transistor (TFT), so that a strength of an electric field that is formed between the channel region and the heavily doped region may be decreased. Thus, it is possible to prevent leakage current due to a short channel effect or a hot electron effect which is caused by a strong electric field. Also, it is not required to use an additional mask so as to form the lightly doped region, so that manufacturing costs are not increased.

[0146] Also, since the lightly doped region may be included, without a burden of additional costs, in a driving transistor that is driven by using relatively large current in an organic light-emitting display device, the organic light-emitting display device may operate more stably.

[0147] While the present invention has been particularly shown and described with reference to exemplary embodi-

ments thereof, it will be understood by those of ordinary skill in the art that various changes in form and details may be made therein without departing from the spirit and scope of the present invention as defined by the following claims.

What is claimed is:

1. A thin film semiconductor device, comprising:
 - a substrate;
 - a first active pattern disposed on the substrate, the first active pattern comprising a channel region, a lightly doped region, and a heavily doped region;
 - a first lower conductive pattern disposed on the first active pattern and covering the channel region; and
 - a first upper conductive pattern disposed on the first lower conductive pattern and covering the channel region and the lightly doped region.
2. The thin film semiconductor device of claim 1, wherein a boundary between the lightly doped region and the heavily doped region is determined in correspondence to an edge of the first upper conductive pattern, and
 - a boundary between the channel region and the lightly doped region is determined in correspondence to an edge of the first lower conductive pattern.
3. The thin film semiconductor device of claim 1, wherein the first active pattern and the first lower conductive pattern configure a first thin film transistor (TFT), and the first lower conductive pattern functions as a gate electrode of the first TFT.
4. The thin film semiconductor device of claim 1, wherein the first lower conductive pattern and the first upper conductive pattern configure a capacitor.
5. The thin film semiconductor device of claim 1, further comprising:
 - a lower gate insulating layer between the first active pattern and the first lower conductive pattern; and
 - an upper gate insulating layer between the first lower conductive pattern and the first upper conductive pattern.
6. The thin film semiconductor device of claim 1, wherein the heavily doped region comprises a first heavily doped region and a second heavily doped region which are respectively disposed at opposite sides of the channel region, and the lightly doped region comprises a first lightly doped region between the channel region and the first heavily doped region, and a second lightly doped region between the channel region and the second heavily doped region.
7. The thin film semiconductor device of claim 1, further comprising:
 - a second active pattern formed from a same layer as the first active pattern, the second active pattern comprising a source region, a drain region, and a channel region between the source region and the drain region; and
 - a second lower conductive pattern formed from a same layer as the first lower conductive pattern and covering the channel region of the second active pattern, wherein the second active pattern and the second lower conductive pattern configure a second TFT, and the second lower conductive pattern functions as a gate electrode of the second TFT.
8. The thin film semiconductor device of claim 7, wherein the second active pattern further comprises a lightly doped region between the channel region and one of the source region and the drain region, and
 - the thin film semiconductor device further comprises a second upper conductive pattern formed from a same

layer as the first upper conductive pattern and covering the channel region and the lightly doped region of the second active pattern.

9. The thin film semiconductor device of claim 8, wherein the second upper conductive pattern is electrically connected to the second lower conductive pattern and thus functions as a common gate electrode of the second TFT.

10. The thin film semiconductor device of claim 8, wherein the second upper conductive pattern floats.

11. An organic light-emitting display device, comprising:

- a substrate;
- a plurality of thin film transistors (TFTs) and a capacitor on the substrate;
- a pixel electrode electrically connected to one of the plurality of TFTs;

a common electrode on the pixel electrode; and
 an intermediate layer disposed between the pixel electrode and the common electrode, the intermediate layer comprising an emission layer (EML),

the plurality of TFTs including a first TFT which comprises a first active pattern comprising a channel region, a lightly doped region, and a heavily doped region, and a first lower conductive pattern disposed on the first active pattern and covering the channel region, and

the capacitor comprising the first lower conductive pattern, and a first upper conductive pattern that is disposed on the first lower conductive pattern and that covers the channel region and the lightly doped region.

12. The organic light-emitting display device of claim 11, wherein a boundary between the lightly doped region and the heavily doped region geometrically corresponds to an edge of the first upper conductive pattern, and

a boundary between the channel region and the lightly doped region geometrically corresponds to an edge of the first lower conductive pattern.

13. The organic light-emitting display device of claim 11, wherein the first lower conductive pattern functions as a gate electrode of the first TFT and a lower electrode of the capacitor.

14. The organic light-emitting display device of claim 11, wherein the heavily doped region comprises a source region and a drain region which are respectively disposed at opposite sides of the channel region, and

the lightly doped region comprises a low-density source region between the channel region and the source region, and a low-density drain region between the channel region and the drain region.

15. The organic light-emitting display device of claim 11, wherein the first TFT is a driving TFT that supplies driving current to the EML.

16. The organic light-emitting display device of claim 11, wherein the plurality of TFTs further comprises a second TFT which comprises a second active pattern that is formed from a same layer as the first active pattern, wherein the second active pattern comprises a source region, a drain region, and a channel region between the source region and the drain region, and a second lower conductive pattern, and wherein the second lower conductive pattern is formed from a same layer as the first lower conductive pattern, covers the channel region of the second active pattern, and functions as a gate electrode of the second TFT.

17. The organic light-emitting display device of claim 16, wherein the second active pattern further comprises a lightly

doped region between the channel region and one of the source region and the drain region of the second TFT, and

the organic light-emitting display device further comprises a second upper conductive pattern formed from a same layer as the first upper conductive pattern and covering the channel region and the lightly doped region of the second active pattern.

18. A method of manufacturing a thin film semiconductor device, the method comprising:

forming an active pattern on a substrate;

forming a lower conductive pattern on the active pattern;

lightly injecting impurities into the active pattern by using the lower conductive pattern as a doping mask;

forming an upper conductive pattern on the lower conductive pattern; and

heavily injecting impurities into the active pattern by using the lower conductive pattern and the upper conductive pattern as doping masks, and forming the active pattern comprising a channel region, a lightly doped region, and a heavily doped region.

19. The method of claim **18**, wherein the lower conductive pattern covers the channel region and does not cover the lightly doped region and the heavily doped region, and

the upper conductive pattern covers the channel region and the lightly doped region, and does not cover the heavily doped region.

20. The method of claim **18**, wherein the forming of the lower conductive pattern comprises forming a lower gate insulating layer on the active pattern, and forming the lower conductive pattern on the lower gate insulating layer, and

the forming of the upper conductive pattern comprises forming an upper gate insulating layer on the lower conductive pattern, and forming the upper conductive pattern on the upper gate insulating layer.

21. The method of claim **18**, wherein the active pattern and the lower conductive pattern configure a thin film transistor (TFT),

the lower conductive pattern and the upper conductive pattern configure a capacitor, and the lower conductive pattern functions as a gate electrode of the TFT and a lower electrode of the capacitor.

* * * * *

专利名称(译)	薄膜半导体器件，有机发光显示器件和制造薄膜半导体器件的方法		
公开(公告)号	US20140225075A1	公开(公告)日	2014-08-14
申请号	US13/944084	申请日	2013-07-17
[标]申请(专利权)人(译)	詹志冯		
申请(专利权)人(译)	詹，志锋		
当前申请(专利权)人(译)	詹，志锋		
[标]发明人	ZHAN ZHI FENG		
发明人	ZHAN, ZHI-FENG		
IPC分类号	H01L51/52 H01L29/786		
CPC分类号	H01L29/78672 H01L2227/323 H01L27/3265 H01L27/3262 H01L27/1255 H01L29/78621 H01L29/66757 H01L29/78645 H01L29/78675		
优先权	1020130016052 2013-02-14 KR		
其他公开文献	US9196737		
外部链接	Espacenet USPTO		

摘要(译)

本发明提供一种薄膜半导体器件，例如有机发光显示器，其包括具有轻掺杂区域的薄膜晶体管（TFT）。薄膜半导体包括基板，第一有源图案，第一下导电图案和第一上导电图案。第一有源图案设置在基板上并包括沟道区，轻掺杂区和重掺杂区。第一下导电图案设置在第一有源图案上并覆盖沟道区。第一上导电图案设置在第一下导电图案上并覆盖沟道区和轻掺杂区。

